

— PROPRIETARY —  
 THIS DOCUMENT CONTAINS CONFIDENTIAL, PROPRIETARY INFORMATION THAT IS FOX PROPERTY. DO NOT DISCLOSE TO OR DUPLICATE FOR OTHERS EXCEPT AS AUTHORIZED BY FOX.

REVISIONS				
ZONE	REV	DESCRIPTION	DATE	APPROVED
	A	RELEASE FOR PRODUCTION	11/09/16	BS
	B	CORRECT WEARBAND, UPDATE DRAWING FORMATE	4/07/20	BS
	C	CHANGED VALVING FROM 50/70 TO 40/80	6/18/21	MG
	D	REPLACED PISTON WAS: 222-01-291 IS: 222-29-002 REPLACED WEARBAND WAS: 002-00-029 IS: 002-05-125 ADDED BLEED SHIM, COMP VALVING CHANGE	2/06/23	NL/BS

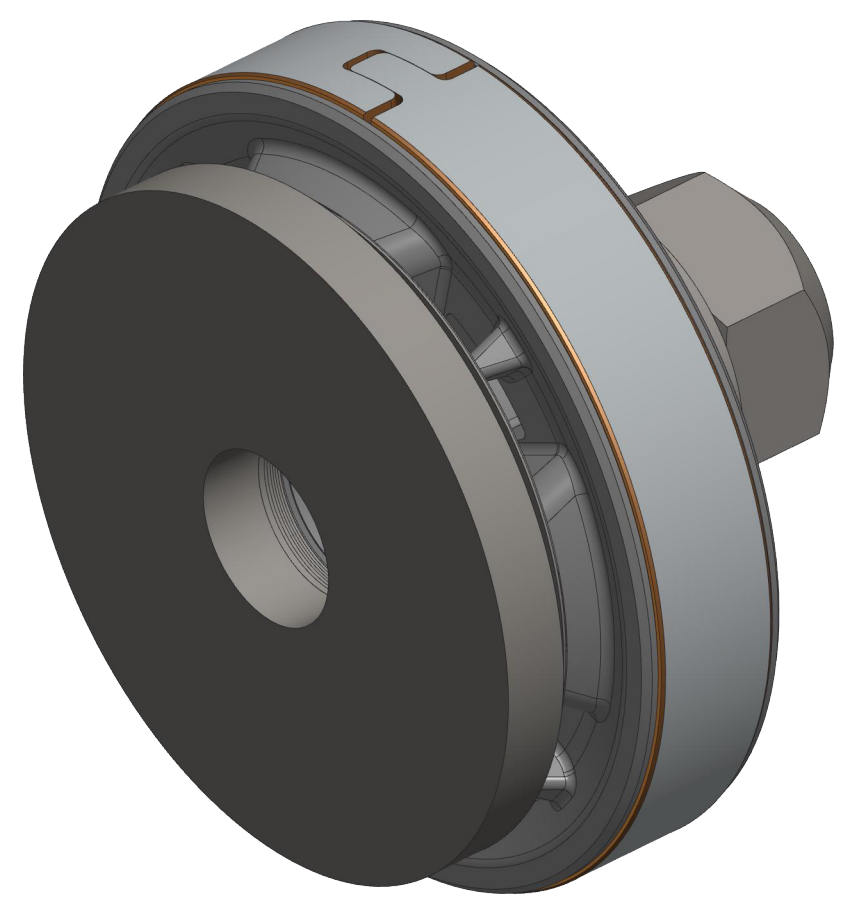

SCALE 2.000

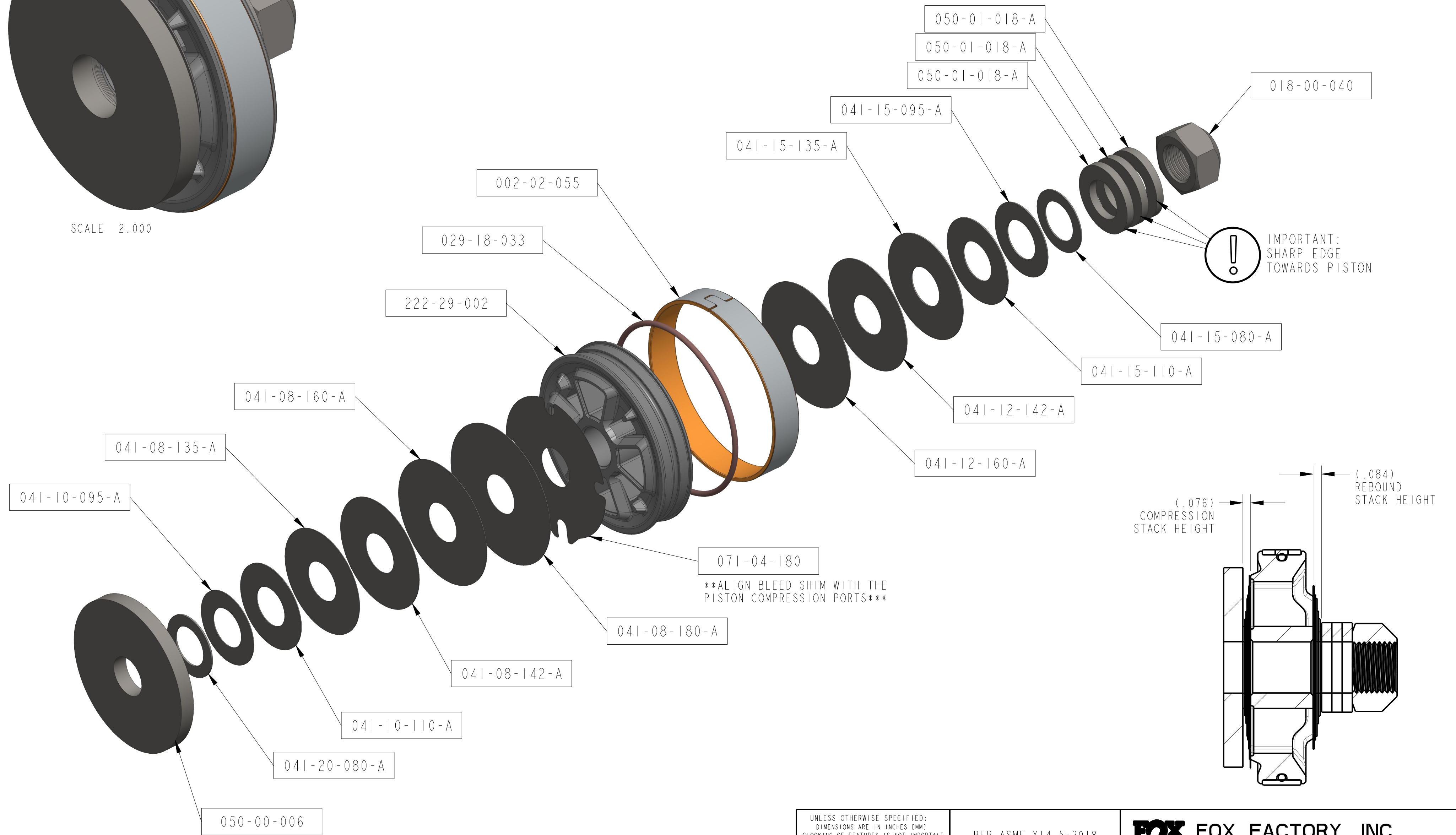

NOTES:  
 1. APPLICATION: 2.5 AIR SHOCK

UNLESS OTHERWISE SPECIFIED: DIMENSIONS ARE IN INCHES (MM) CLOCKING OF FEATURES IS NOT IMPORTANT		PER ASME Y14.5-2018		<b>FOX FACTORY, INC.</b>	
DEV PROJECT #:		APPROVALS		TITLE	
TOLERANCES ARE:		DWN. BY E. KENYA		Valving Assembly: 2.5 Factory Series, Tuned Combination 304	
DECIMALS .XX [.X] ±.01 [0.25]		CHK. BY		SIZE C	
ANGLES ± 1°		ENG. B. SMITH		DWG. NO. 807-24-304	
THIRD ANGLE PROJECTION		MFG.		PLOT SCALE: 1.250	
PROTO / MAKE FROM PN: XXX-XX-XXX		QC.		SHEET: 1 OF 2	

4

3

2

1

— PROPRIETARY —  
THIS DOCUMENT CONTAINS CONFIDENTIAL, PROPRIETARY INFORMATION THAT IS FOX PROPERTY. DO NOT DISCLOSE TO OR DUPLICATE FOR OTHERS EXCEPT AS AUTHORIZED BY FOX.

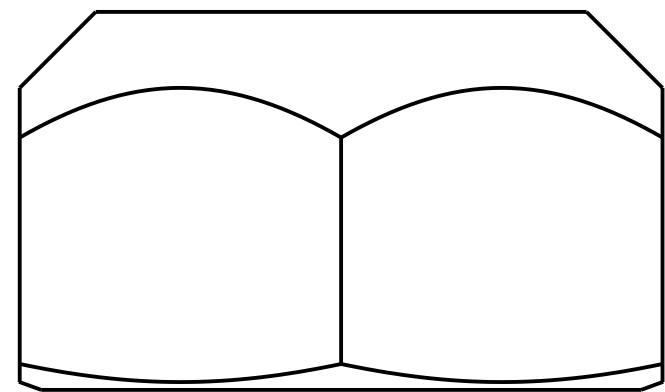

3X BACK UP WASHER

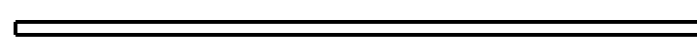

0.800 X .015

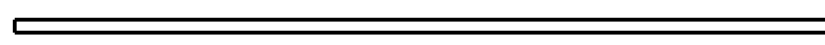

0.950 X .015

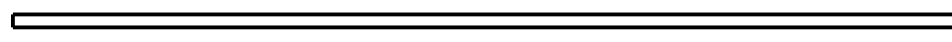

1.100 X .015

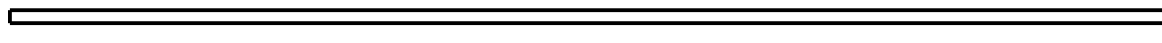

1.350 X .015



1.425 X .012

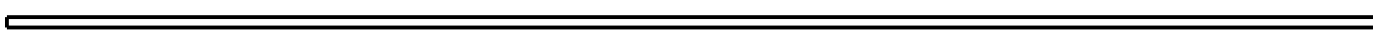

1.600 X .012

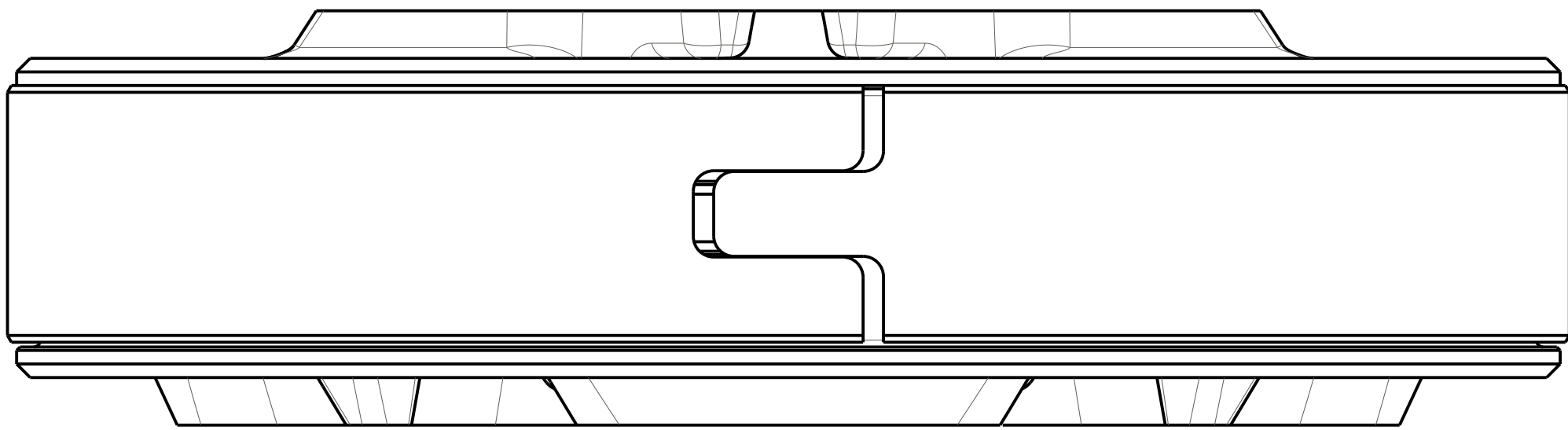

1.800 X .004 BLEED SHIM

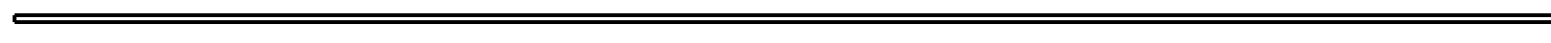

1.800 X .008

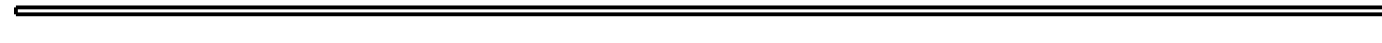

1.600 X .008



1.425 X .008



1.350 X .008

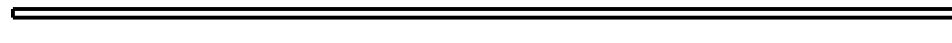

1.100 X .010

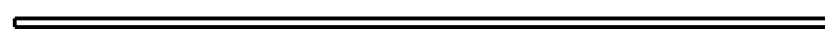

0.950 X .010

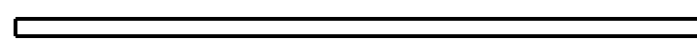

0.800 X .020



TOP OUT WASHER

SIZE	DWG. NO.	REV
C	807-24-304	B
PLOT SCALE: 1.50:1		SHEET: 2 OF 2

4

3

2

1